

USB2 - InGaAs 256

Complete medium speed, low noise InGaAs linescan camera system for the near infrared



Key Features:

- InGaAs line scan camera system.
- 256 Pixels low noise.
- Drivers for W98 / W2K / XP/ Labview.

Applications:

- Spectroscopy.
- Portable applications.
- Beam Profiler.

Overview:

The USB-InGaAS 256 is an easy to use, complete linescan camera-system for the near infrared. It includes a low noise InGaAs linescan camera with an USB 2.0 interface. Additional components are not required.

The USB-InGaAs was designed for low speed applications with the need of high sensitivity and low noise, like spectroscopy.

Hardware:

The USB-InGaAs camera head includes the complete sensor timing with signal conditioning (CDS), a precision 16 Bit ADC and an USB 2.0 interface.

The camera head is powered by the USB-bus. Additional power-supplies are not required. The USB-CCD provides optional start of scan output and an input for external triggering.

Software

The USB2-InGaAs linescan camera system is shipped with a software for Windows 98, Windows 2000 and XP.

The software includes a DLL to provide an interface to other software and an user software. Drivers for Labview are available upon request.

The user software includes various modes to edit the x/y scales and units, a run mode to observe the sensors's signal, signal processing functions like averaging, binning and x/y zoom and a function to subtract a reference from the actual scan. To get a zero baseline at once, the reference can be loaded from the actual scan. This function works with floating point accuracy.

The two averaging modes provide functions for further reducing the signal to noise ratio.

The integer accumulation mode performs a fast accumulation of several scans.

The averaging mode calculates the running mean of consecutive displayed scans. This floating point function performs (with the excellent integral linearity of the ADC) a baseline stability of 1/2 LSB. (This is possible for very slow processes only.)

To provide a stable display of non-repetitive signals (like a laser beam crossing the sensor chip), a software trigger was included. Only these scans are displayed (and averaged) which pixels exceeding a selectable threshold .

The view modus provides functions to read and print stored files from disk. The file format for stored data is ASCII, to facilitate the data transfer to other programs like Excel.

Mechanical Dimension

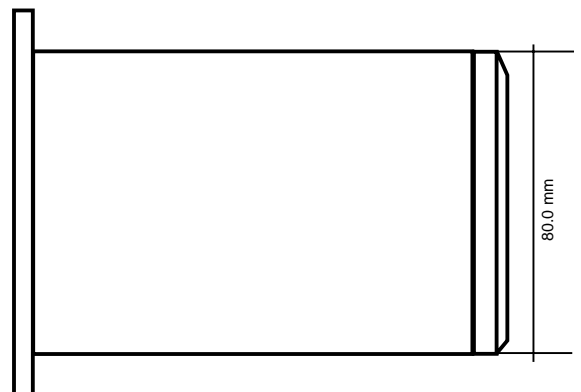
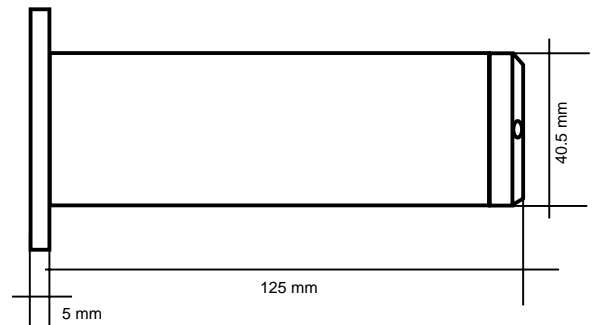
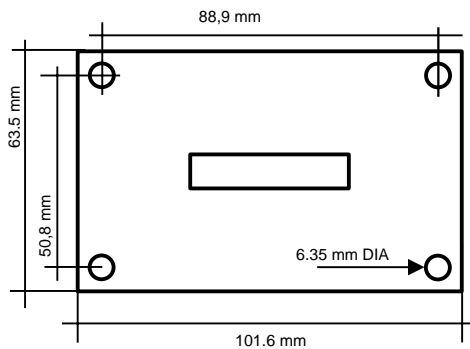

Specifications

Detector array:

Number of pixels: 256
 Pixel size: 50 μm x 250 μm
 Spectral range: < 900 nm..1670 nm
 Sensitivity nonuniformity: < 10% ss
 Defective Pixels < 5 %

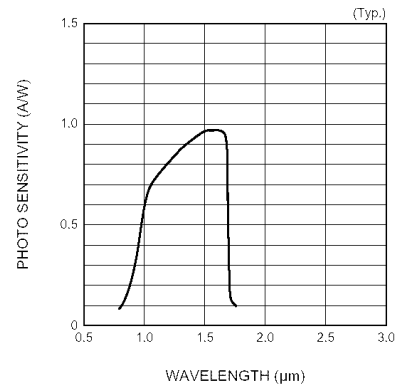

System & detector:

Signal / Noise pp: about 1600 : 1.
 Signal / Noise rms about 16000 : 1.
 Exposure Time: 4 ms to 1,0 s.
 Framerate: about 200 lps.

System requirements:

Operating system: Win 98 / 2000.
 Disk: 300 KB free.

USB interface:

USB: 2.0.
 Required Current: 500 mA.
 Optional:
 Trigger: Input TTL.
 Start of scan: Output TTL.

Software:

Software includes: User software,
 DLL interface,
 Driver for Labview
 upon request.

User software:

X scale edit: Enter start and stop.
 Enter the values at two
 cursor positions.
 Y scale edit: Enter start and stop.
 Enter the values at two
 cursor positions.
 X / Y unit edit: Enter units.
 Averaging: Integration of several
 scans (up to 15).
 Running mean of n
 consecutive scans.
 Binning: Up to 64 pixels.
 Display options: Display actual scan.
 Load reference from
 actual scan and display
 scan minus reference.
 Set reference to zero.
 Data operations: Write to disk.
 Write consecutive
 scans to disk.
 Read from disk.
 Print scan.